

- Contactless design – Inductive technology
- Wear-free operation
- Stroke lengths up to 1,800mm
- 10.1mm body diameter
- Absolute measurement
- Infinite resolution
- High temperature capability – Up to 200°C or down to -55°C
- Working pressures up to 670Bar
- Separate signal conditioning (EICT)
 - High performance driver circuit
 - Zero and span adjustment
 - Choice of enclosure designs



The ICT100 Contactless In-Cylinder Linear Transducer has been specifically designed for mobile and static hydro-pneumatic actuators.

Designed primarily for the off-highway markets, the ICT100 linear transducer provides reliable, fit-and-forget position sensing of the cylinder rod in actuators with strokes up to 1,800mm, with a body diameter of only 10.1mm.

It is a robust, non-contact transducer suitable for the harsh conditions of lifting and steering position applications and hydro-pneumatic active suspension systems. It works on an inductive coil principle, with virtually infinite resolution and is capable of withstanding temperatures down to -55°C and up to +200°C, with working pressures to 670Bar (10,000psi).

The EICT signal-conditioning module has been specifically designed to operate with the Penny and Giles range of SLT and ICT contactless linear position transducers.

The module incorporates a high performance circuit that drives the transducer and provides a choice of output signals with zero and span adjustment for simple user configuration. The module can be supplied in a choice of enclosures, with sealing to IP66 or IP68 protection.



CONTENTS

Configuration & Ordering Codes	3
Flange.....	3
Core	3
Electrical Length.....	3
Linearity.....	4
Temperature Range	4
Cable Length.....	4
Signal Conditioning Module	4
Installation	5
Sensor Mechanical Dimensions	5
Threaded Core.....	5
Sleeved Core.....	6
Sensor Installation kit	7
Suggested Sensor Fitting Profiles.....	7
Internal Flange Machining Details.....	7
Threaded Flange Machining Details.....	8
Sleeved Core Machining Details	8
Threaded Core Machining Details	9
Signal Conditioning Module Mechanical Dimensions.....	9
EICT.....	9
EICTM	10
Electrical Connections.....	10
Wiring Notes	11
Signal Conditioning Module Set-Up.....	11
Rapid Integrity Check for Transducer	13
Specifications	14
Electrical.....	14
Outputs	14
Mechanical	15
Environmental	15

© 2023 Curtiss-Wright. All rights reserved.

Curtiss-Wright accepts no responsibility for possible errors in catalogs, brochures and other printed material. Curtiss-Wright reserves the right to alter its products without prior notice. This also applies to products already Ordered provided that such alterations can be made without affecting agreed specifications.

All trademarks in this material are properties of their respective owners.



CONFIGURATION & ORDERING CODES

ICT100-XX-XX-XXXX-X-X-XX

Type	Flange	Core	Electrical Length	Linearity	Temperature Range	Cable Length
ICT100	XX	XX	XXXX	X	X	XX
	IN	SC	0025-2000	A	H	01
	EM	TM		B		04
	EU	TU			06	
	RM					
	RU					

FLANGE

ICT100-XX-XX-XXXX-X-X-XX

Code	Description
IN	Internal flange
EM	External flange – metric
EU	External flange – unified
RM	Reverse threaded flange – metric
RU	Reverse threaded flange – unified

CORE

ICT100-XX-XX-XXXX-X-X-XX

Code	Description
SC	Sleeved core
TM	Threaded core – metric
TU	Threaded core – unified

ELECTRICAL LENGTH

ICT100-XX-XX-XXXX-X-X-XX

Code	Description
XXXX	25mm to 200mm full electrical stroke length selectable in 5mm increments
	210mm to 1100mm full electrical stroke length selectable in 10mm increments
	1120mm to 1800mm full electrical stroke length selectable in 20mm increments

Stroke length is always written as four digits e.g. 80mm = 0080 and 880mm = 0880

**LINEARITY**ICT100-XX-XX-XXXX-X-X-XX

Code	Description
A	±0.25% total stroke maximum, typically less than ±0.20%
B	±0.50% total stroke maximum, typically less than ±0.25%

TEMPERATURE RANGEICT100-XX-XX-XXXX-X-X-XX

Code	Description
H	-20°C to +200°C operating temperature

CABLE LENGTHICT100-XX-XX-XXXX-X-X-XX

Code	Description
01	1.0m flying lead
04	4.0m flying lead
06	6.0m flying lead

SIGNAL CONDITIONING MODULE

The ICT100 requires one of the following signal conditioning modules (ordered separately)

Code	Description
EICT	Corrosion resistant plastic enclosure sealed to IP66, with detail to fit rail DIN EN50022 or EN50035 or bulkhead mount via four M5 screws
EICTM	Powder coated metal enclosure sealed to IP68 with bulkhead mounting via four M5 screws

The following accessories for the signal-conditioning module are also available (ordered separately)

Code	Description
VM	Voltage module output option card
CM	Current module output option card
PWM	Pulse width modulation output option card



INSTALLATION

SENSOR MECHANICAL DIMENSIONS

Threaded Core

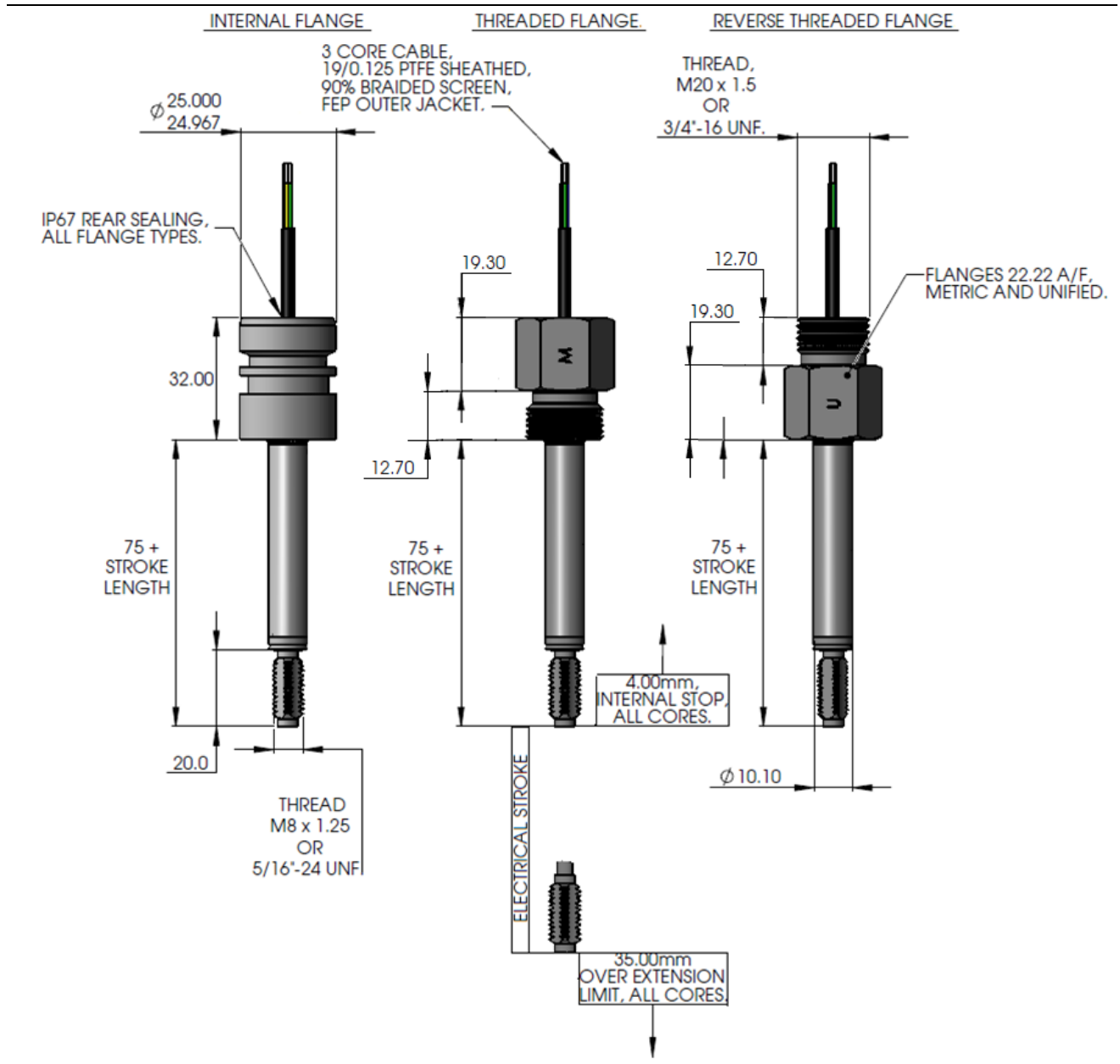



Sleeved Core

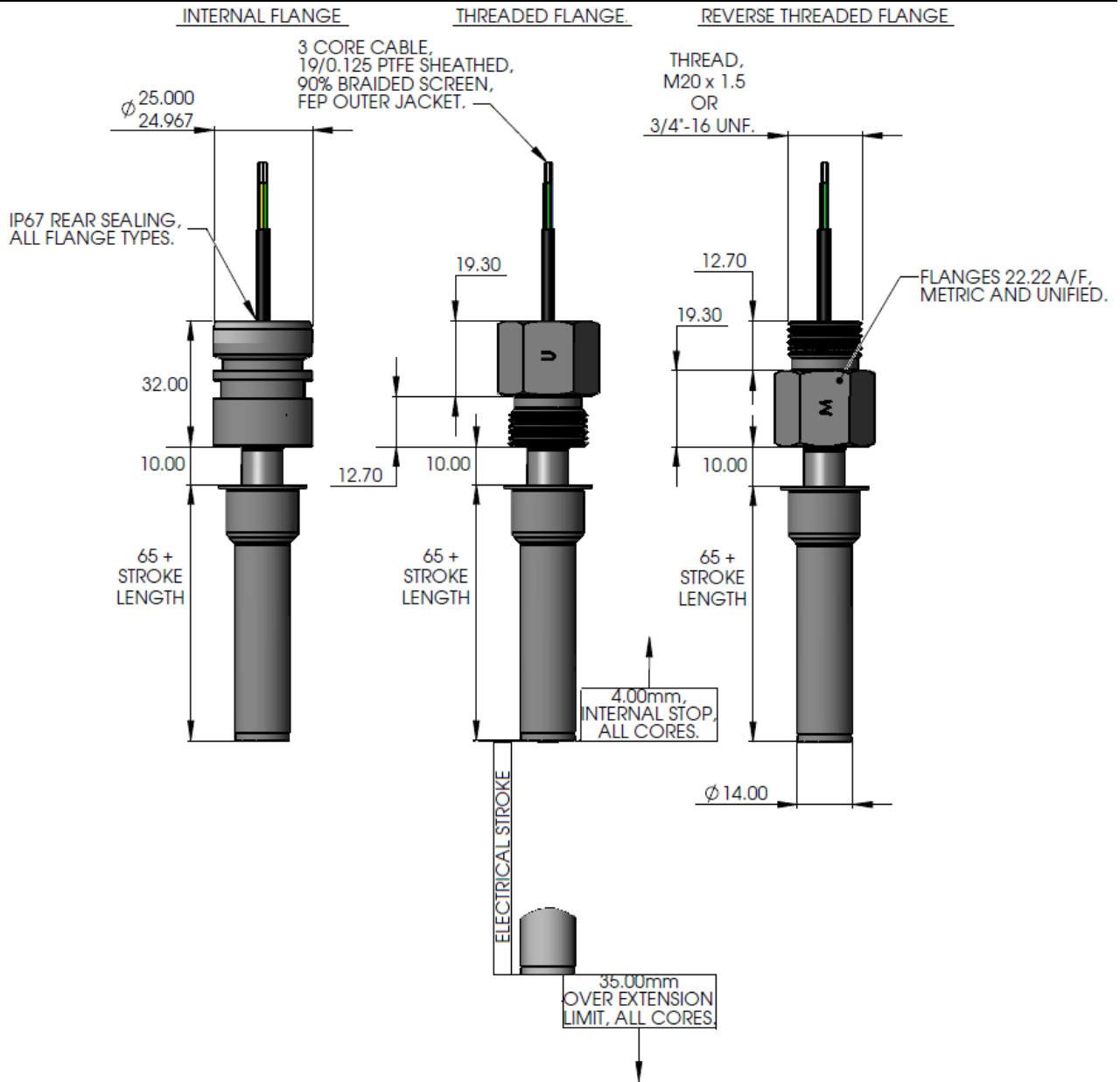



SENSOR INSTALLATION KIT

The installation kit is dependent upon the temperature rating. AI202800 applies for the H option and AI207803 applies for the L option in the configuration code.

Item Number	Description	P&G Part Number		Quantity
		AI202800 (H option)	AI207803 (L option)	
1	Full nut M8 x 1.25	X63-072-380	X63-072-380	1
2	Full nut 5/16" – 24 UNF	X63-111-002	X63-111-002	1
3	Wavy washer	X63-112-012	X63-112-012	3
4	Shim washer	P202677	P202677	1
5	Circlip	X69-005-107	X69-005-107	1
6	O-ring 17 x 2	X64-194-007	X64-213-007	1
7	O ring 21x 2.5	X64-194-009	X64-213-009	1
8	Anti-extrusion ring	X64-074-003	X64-074-003	1
9	M5 conical set screw	X63-096-506	X63-096-506	1
10	Copy of installation drawing	AI202800	AI207803	1
11	Label – supplied loose	P200919	P200919	1
12	Installation kit label	P203193	P207804	1

Item 11 (Label) is supplied for the customer to record ICT ordering code and is to be fitted in visible location adjacent to sensor for re-ordering reference

SUGGESTED SENSOR FITTING PROFILES

The installation details shown here are suggestions only because of the multiplicity of potential applications. The user should ensure that the design, method of assembly and materials used are satisfactory for the installation.

Internal Flange Machining Details

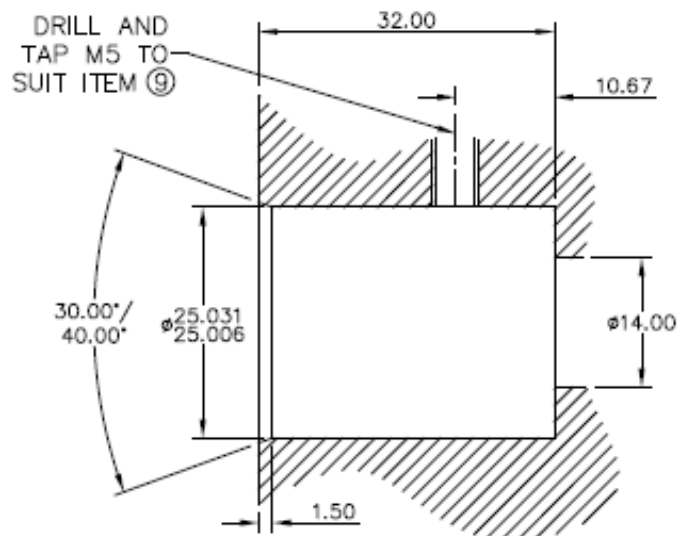

To seal use items 7 and 8 from the appropriate installation kit



Threaded Flange Machining Details

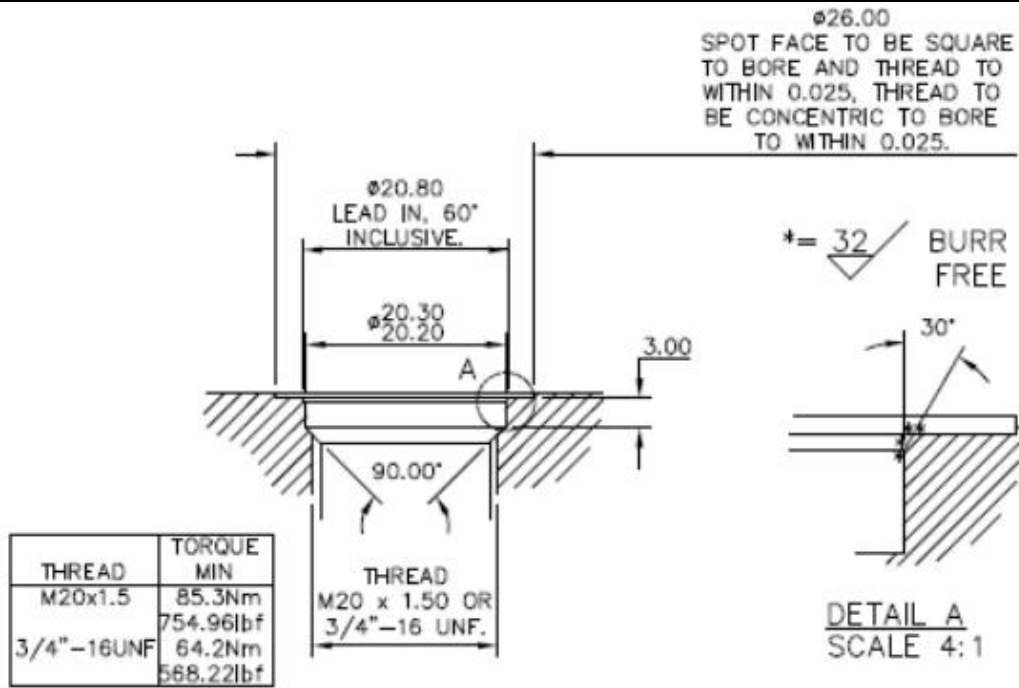

To seal use item 6 from the appropriate installation kit

Sleeved Core Machining Details

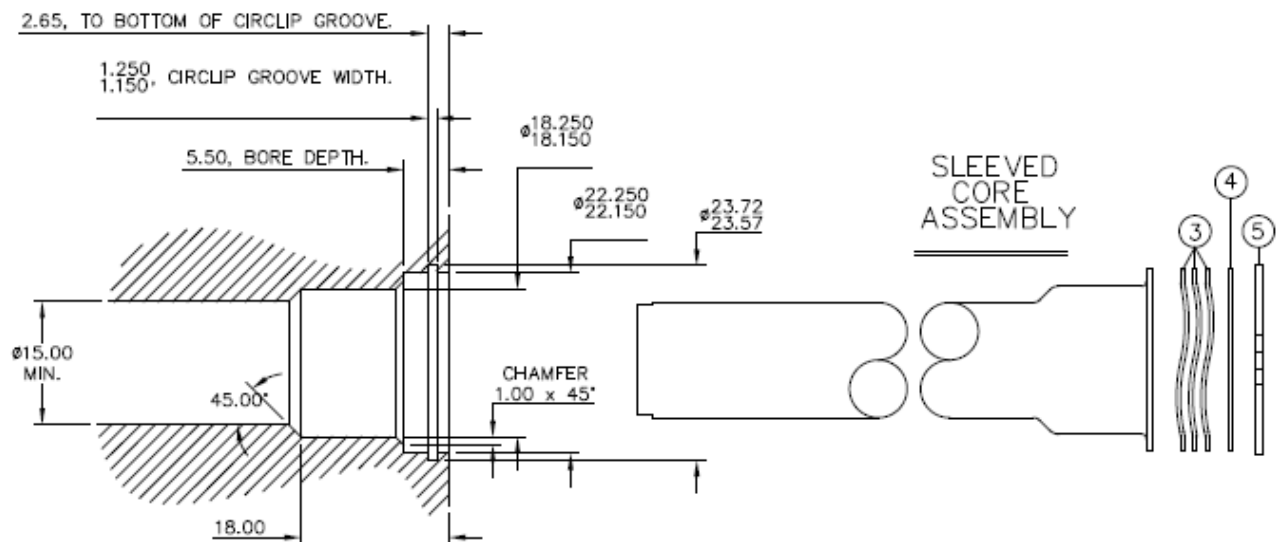

Threaded Core Machining Details

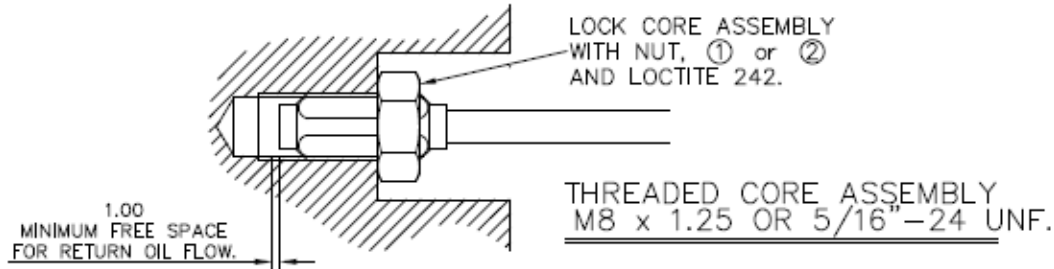

SIGNAL CONDITIONING MODULE MECHANICAL DIMENSIONS

EICT

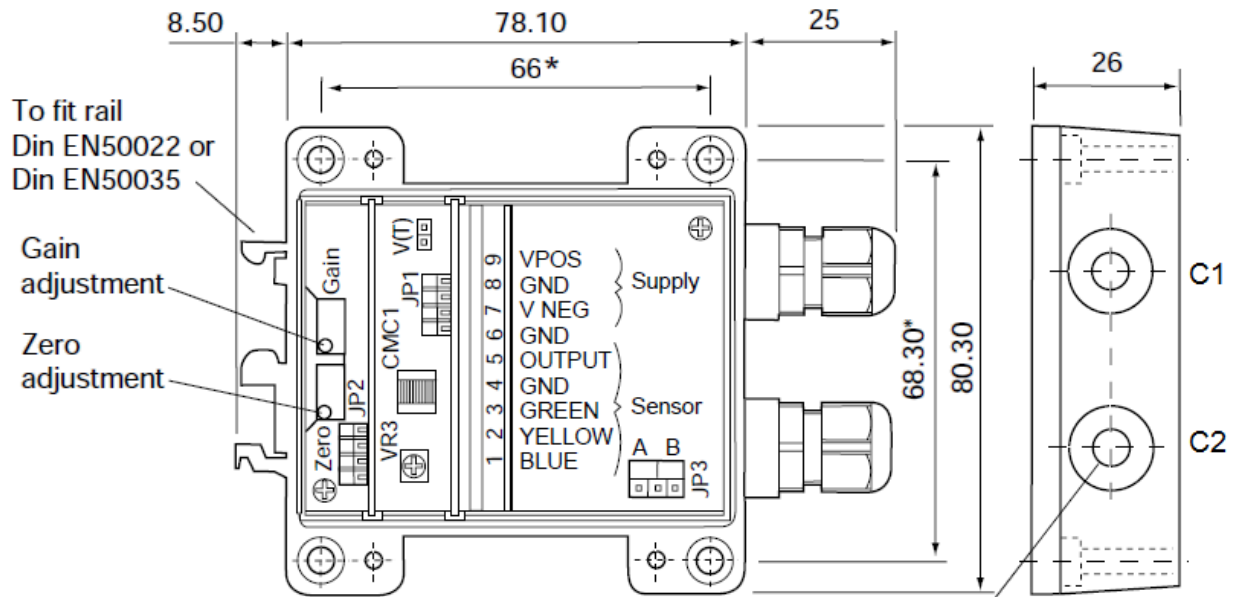

*Bulkhead fixing dimensions
Enclosure provided with four fixing holes to accept M5 screw x 30mm long minimum.

Cable glands Cable diameter must be between 2.5 and 6.0mm diameter to maintain IP66 rating of the enclosure.

Cover removed for illustrative purposes

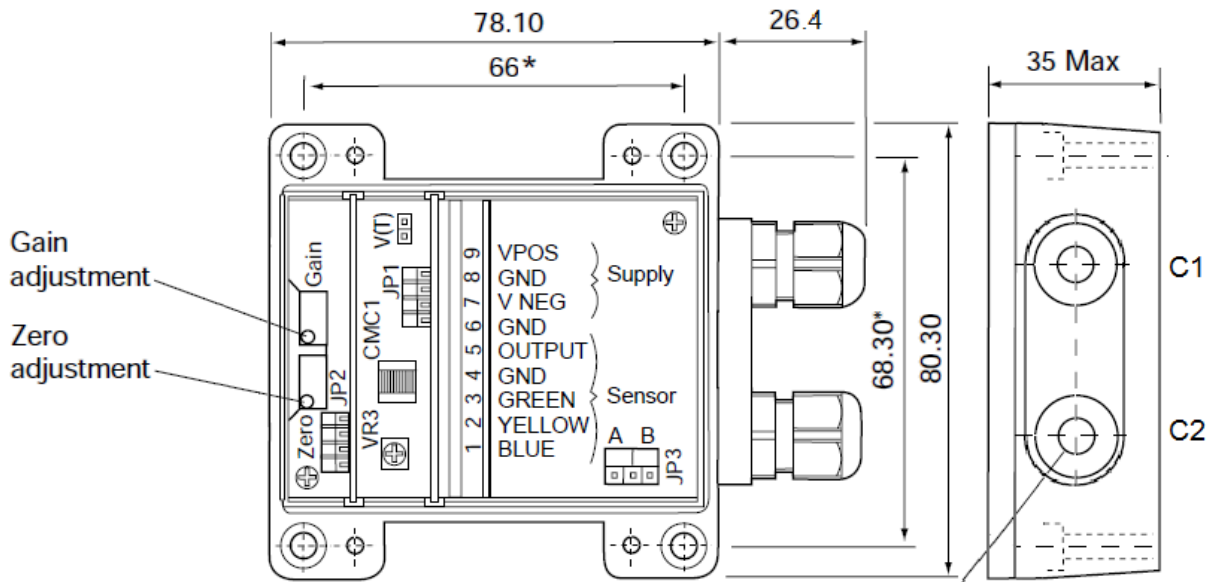
EICTM

*Bulkhead fixing dimensions
Enclosure provided with four fixing holes to accept M5 screw x 30mm long minimum.

Cable glands Cable diameter must be between 3.0 and 8.0mm diameter to maintain IP68 rating of the enclosure.

Cover removed for illustrative purposes

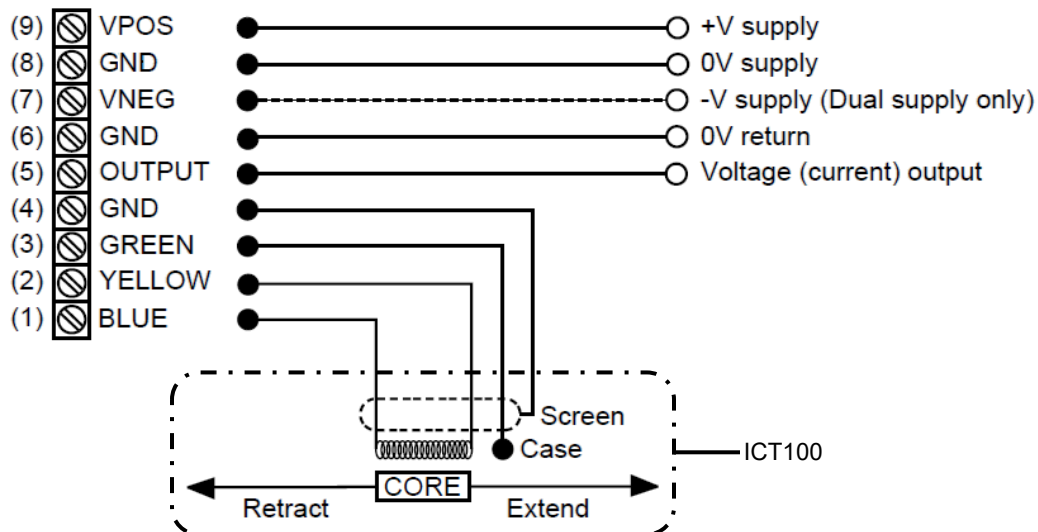
ELECTRICAL CONNECTIONS

Wiring Notes

- The green wire is internally connected to the transducer case. Due to the construction of the transducer external moving parts, the green connection should not be used as a ground connection.
- The enclosure is not connected internally to ground, so it can be mounted on a chassis carrying a voltage potential other than 0Vdc
- Misconnection of the supply may cause permanent damage.
- Maximum recommended distance between transducer and signal conditioning module is 10m.
- Each transducer is supplied with a sensor calibration module card (SCMC), calibrated to match the electrical stroke length. The EICT and EICTM will only drive the ICT or SLT transducers correctly when the SCMC is fitted on header JP1. It is important that the transducer stroke length and the sensor length module be matched.
- The EICT/EICTM, with or without option cards fitted, requires only a single supply voltage connected between GND and VPOS.
- When the VM (Voltage Module) option card is used, an internal negative rail generator enables zero and negative output voltages to be achieved.
- In some situations an external negative supply in the range -10V to -30Vdc may be available (e.g., where the EICT is being used to replace an earlier model of signal conditioner). It is permissible to connect this voltage to VNEG, in which case the internal negative supply generator on the VM option card will be disabled and current will be drawn from the external supply.

SIGNAL CONDITIONING MODULE SET-UP

- STEP 1**
- Remove the four retaining screws to release the lid from the enclosure base. Note the position of the gasket in the lid.
 - Identify the Sensor Calibration Module Card (SCMC) supplied with the transducer.
 - Insert the SCMC card into position JP1.
- STEP 2**
- Unscrew the cable glands and pass the power supply cable through gland C1 into 'SUPPLY' zone on the EICT/EICTM board.
 - Do not turn on the power until instructed as incorrect connections may destroy the EICT/EICTM on power up.
 - Connect the power supply lead carrying the most POSITIVE potential (e.g. +24Vdc) to Terminal 9 [VPOS].
 - Connect the power lead carrying 0V to Terminal 8 [GND].
 - If using a dual supply, connect most negative power lead (e.g. -15V) to Terminal 7 [VNEG].
 - A power supply cable screen can be connected to Terminal 6 [GND]. This is recommended but optional.
 - Firmly tighten cable gland lock nut C1.
- STEP 3**
- Pass the transducer cable through gland C2 into 'SENSOR' zone on EICT/EICTM board.
 - Connect the transducer to the terminals on the EICT/EICTM board as per the electrical connections diagram.
 - Firmly tighten cable gland lock nut C2.
- STEP 4**
- Locate jumper on header JP3 on EICT/EICTM board. This determines the gradient of the voltage/current output with respect to the transducer core motion. Locate the jumper in the required position.



- The EICT/EICTM is factory set with JP3 in position 'A'
- STEP 5**
- If the required output signal is 0.5 - 4.5Vdc or 4 - 20 mA or TTL level (i.e. no Voltage Module (VM) output option card is fitted), fit the jumper into position on header JP2 (across terminals 1 & 2). The EICT/EICTM is factory set with the jumper fitted in this position.
 - If the required output signal is a voltage signal other than 0.5 - 4.5Vdc (i.e. an additional VM output option card is required) then remove jumper from header JP2 and store on V(T) link park terminals.

- STEP 6**
- VM card only, for all other options proceed to step 7.
 - Select the Voltage Module (VM) output option card and locate the DIP switch (SW1) on the card. Select the required sensor output voltage and, using the Switch Position Matrix Guide below, set the DIP switch positions accordingly.

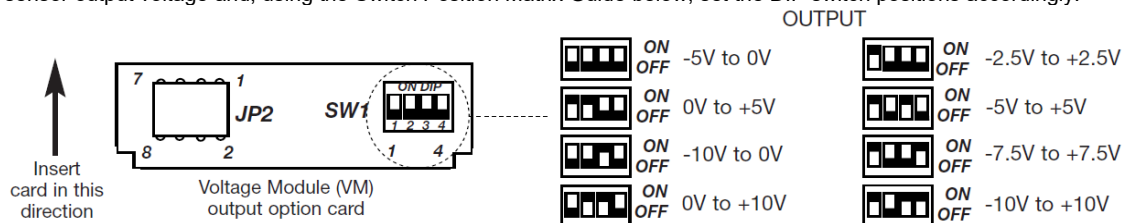

- STEP 7**
- If using a voltage module, connect the VM card by inserting connector into position on header JP2 of EICT/EICTM PCB. Do not insert CM or PWM cards at this stage.
 - Connect a DMM set to measure voltage to the output (terminal 5) and GND (terminal 6) on the EICT/EICTM PCB.
 - Move the transducer core to the fully 'Lo' position (See Step 4 and Fig. 2) and power up the EICT/EICTM.
 - Adjust ZERO trim pot until the required output voltage is achieved on the DMM display (0.5Vdc if no VM card is fitted in JP2).
 - For Dual Supply option, output over the full range, relative to ground ('GND' 0V) will appear on Terminal 5 'OUTPUT'. (e.g. In the case of a -10V to 0 to +10V range, the output can be trimmed to -10V using the ZERO trim pot).
- STEP 8**
- Move the transducer core to the fully 'Hi' position and adjust GAIN trim pot until required output voltage is achieved (4.5Vdc if no VM card is fitted in JP2).
 - For Dual Supply option, output over the full range, relative to ground ('GND' 0V) will appear on Terminal 5 'OUTPUT'. (e.g. In the case of a -10V to 0 to +10V range, the output can be trimmed to +10V using the GAIN trim pot).
- STEP 9 – CM CARD**
- If using a PWM card follow the process in STEP 9 PWM CARD.
 - If no card is used, proceed to step 10.
 - If a current output is required, Switch off the power supply to EICT/EICTM, remove jumper from header JP2 and store on V(T) link park terminals.
 - Connect the CM card by inserting connector into position on header JP2 of EICT/EICTM PCB.
 - Change DMM (already connected between terminals 5 and 6) range settings to measure a 4-20mA current output and power up the EICT/EICTM.
 - Check that the output is 4-20mA over the stroke of the transducer core.
 - If adjustment is required, move transducer core to the fully 'Lo' position and Adjust ZERO trim pot until the required output current (4mA) is achieved and/or move transducer core to the fully 'Hi' position and adjust GAIN trim pot until required output current (20mA) is achieved.
- STEP 9 – PWM CARD**
- If using a CM card follow the process in STEP 9 CM CARD.
 - If no card is used, proceed to step 10.
 - If a pulse width modulation output is required, Switch off the power supply to EICT/EICTM, remove jumper from header JP2 and store on V(T) link park terminals.
 - Select the Pulse Width Modulation Module (PWM) output option card and locate the DIP switch (S1) on the card. Select the required sensor output frequency and, using the matrix table printed on the card, set the DIP switch positions accordingly.

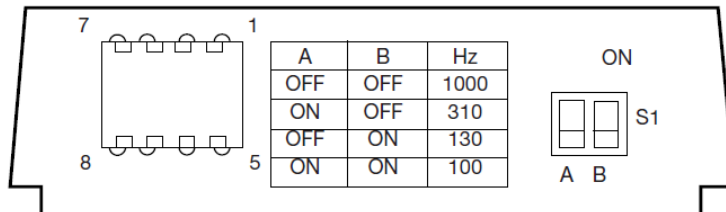

- Connect the PWM card by inserting connector into position on header JP2 of EICT/EICTM PCB.
 - Replace the DMM (already connected between terminals 5 and 6) with an oscilloscope and power up the EICT/EICTM.
 - Check that the output has 10-90% duty cycle over the stroke of the transducer core.
 - If adjustment is required, move transducer core to the fully 'Lo' position and Adjust ZERO trim pot until the required output (10%, equivalent to 0.5Vdc) is achieved and/or move transducer core to the fully 'Hi' position and adjust GAIN trim pot until required output (90%, equivalent to 4.5Vdc) is achieved.
- STEP 10**
- After configuration, switch off the power to EICT/EICTM and remove DMM or oscilloscope connections.
 - Replace the lid using screws removed, ensuring all gaskets are present and in the correct place. Recommended tightening torque for the lid screws is 2Nm.
 - Optional, but recommended - use an indelible pen to mark the configuration settings in the appropriate label area shown on the EICT/EICTM housing cover. (EICT type; Voltage output range [if applicable]; transducer type).
 - The transducer and EICT/EICTM are now ready for use.



RAPID INTEGRITY CHECK FOR TRANSDUCER

- EICT/EICTM must be disconnected from the transducer to carry out following check.
 - Using a DMM, set to the resistance range:
 - Measure between connections assigned to transducer 'yellow' and 'blue'. Value should lie between 40Ω and 170Ω.
 - Measure between connections assigned to transducer 'green' and 'yellow' and/or 'blue'. Value should be 'open circuit'.
 - Measure between connections assigned to 'green' and the transducer body. Value should be 'short circuit'.
 - 'Screen', if used - Connections assigned to 'screen' should be 'open circuit' to all the other electrical connections and transducer body unless otherwise specified by your Systems Engineer.
-



SPECIFICATIONS

ELECTRICAL

MEASUREMENT RANGE	Maximum stroke selectable up to 1800mm
SENSOR RESOLUTION	Infinite
LEAST SQUARES LINEARITY	Refer to ordering code
INSULATION RESISTANCE	Yellow / blue to case >50MΩ at 50Vdc Screen to case >50MΩ at 50Vdc
GREEN WIRE BONDING RESISTANCE	< 1+ (0.08 x cable length in metres) Ω
SUPPLY VOLTAGE	10-60Vdc unregulated for standard voltage output (EICT/EICTM only) 10-30Vdc unregulated for extended voltage output group 1 (VM card fitted) 13.5-30Vdc unregulated for extended voltage output group 2 (VM card fitted) 10-30Vdc unregulated for current output (CM card fitted) 10-30Vdc unregulated for pulse width modulated output (PWM card fitted) Or ±10-30Vdc unregulated (all configurations expect voltage group 2) ±13.5-30Vdc unregulated (extended output voltage group 2)
SUPPLY CURRENT	10mA maximum (EICT/EICTM only) 19mA maximum (VM card fitted) 12.6mA maximum plus output current (CM card fitted) 13mA maximum (PWM card fitted)
POWER-ON SETTLEMENT	<300ms (within 0.25% of final output)
SENSOR TEMPERATURE COEFFICIENT	<±100ppm of electrical stroke /°C (+20°C to +60°C) <±200ppm of electrical stroke /°C (-20°C to +100°C) <±300ppm of electrical stroke /°C (-20°C to +200°C)
EICT/EICTM TEMPERATURE COEFFICIENT	<±200ppm/°C <±300ppm/°C if fitted with VM card
LINE REGULATION	<0.001% output span/volt

OUTPUTS

STANDARD VOLTAGE OUTPUT	0.5-4.5Vdc (EICT/EICTM only)
EXTENDED VOLTAGE OUTPUT GROUP 1	0-5Vdc (VM card fitted) ±2.5Vdc (VM card fitted) ±5Vdc (VM card fitted)
EXTENDED VOLTAGE OUTPUT GROUP 2	0-10Vdc (VM card fitted) ±7.5Vdc (VM card fitted) ±10Vdc (VM card fitted)
CURRENT OUTPUT	4-20mA
PULSE WIDTH MODULATION OUTPUT	TTL level compatible signal with a 10-90% duty cycle
OUTPUT FREQUENCY	100, 130 310 or 1000Hz (user selectable)
FREQUENCY ACCURACY	±10%
LOGIC HIGH OUTPUT LEVEL	4.5±0.5Vdc
LOGIC LOW OUTPUT LEVEL	<0.4Vdc
RISE/FALL TIME	<2µs with 1nF load capacitance
OUTPUT RANGE	10% (zero) to 90% (span)
OUTPUT NOISE	<5mVrms
OUTPUT LOAD	10kΩ minimum resistive to 0V line
OUTPUT ADJUSTMENT RANGE	Minimum sensor range is 50% of nominal sensor range
ZERO ADJUSTMENT	-10 to 60% of span, approximately 20 turns on adjustment pot
GAIN ADJUSTMENT	40 to 110% of span, approximately 20 turns on adjustment pot
FREQUENCY RESPONSE	30Hz (-3dB), equivalent to 5ms output lag

**MECHANICAL**

MAXIMUM SENSOR WORKING PRESSURE	670Bar
EICT/EICTM BULKHEAD MOUNTING SCREW TORQUE	4Nm
EICT/EICTM LID SCREW TORQUE	2Nm, ensure that the rubber seal is properly located in the lid groove prior to re-fitting

ENVIRONMENTAL

SENSOR TEMPERATURE RANGE	Operating: Refer to ordering code Storage: -55°C to +200°C
EICT/EICTM TEMPERATURE RANGE	Operating: 0°C to +70°C Storage: -40°C to +85°C
SEALING	EICT – IP66 EICTM – IP68 Users should also ensure adequate sealing of the opposite end connections on supply, transducer and output cables to ensure moisture cannot migrate down the inside of the cables into the EICT/EICTM module.
ELECTROMAGNETIC INTERFERENCE	EN61000-6-2, 100V/m (EICTM adjacent to transducer) Derangement <0.05% FS EN61000-6-2, 10V/m (EICT 1m cable to transducer) Derangement <0.05% FS

IMPORTANT INFORMATION

Whilst Curtiss-Wright Industrial Division - Penny & Giles has designed this sensor to meet a range of applications it is the responsibility of the customer to ensure it meets their specific requirement.

Penny & Giles Controls Ltd makes no warranty or representation in respect of product fitness or suitability for any particular design application, environment, or otherwise, except as may subsequently be agreed in contract for the sale and purchase of products. Customers should therefore satisfy themselves of the actual performance requirements and subsequently the product's suitability for any particular design application and the environment in which the product is to be used.

Continual research and development may require change to products and specification without prior notification.

All trademarks acknowledged.